



TFLBDI

*Vertically Polarized 87.5 - 108 MHz
Omni-directional, Stainless Steel
Broadband FM Dipole Antenna*



- Lightning Protection – All metal parts DC grounded
- Null fill, beam tilt & custom applications upon request
- Pressurization available upon request
- Optional mini feedpoint radome available
- Impedance: 50 Ohm • VSWR: < 1.35: 1
- Input connector (each bay): “N” Type fem. or 7-16 or 7/8” Flange
- Typical center to center distance: (multi-bays) 8 ½ ft (2.6 m.)
- Bracket: can clamp on 1” to 4 3/16” (25mm to 110mm) diam.
- Typical weight: (1 bay) 24 Lbs / 11 Kg (boxed)
- Approx size: (1 bay) 41¾” x 54” x 2½” (1060mm x 1370mm x 63mm)
- Typical boxed size: (1 bay) 63”x 50”x 6” (1600mm x 1270mm x 152mm)
- Pattern: Omni-directional +/- 3 dB typical on a standard 4”/100mm steel pole support

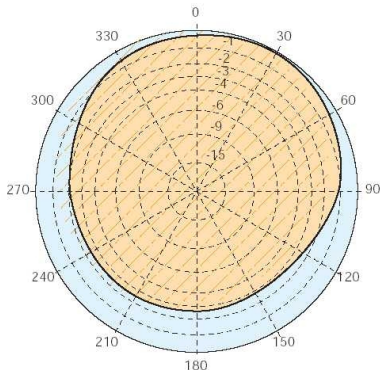

**Typical mid-band
radiation pattern
< H-Plane
E-Plane >
(each bay)**

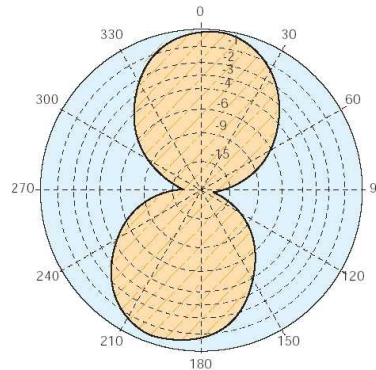

N. of Bays	Gain (dBd)	Power Gain	Gain (dbi)	“N” Pwr Rating	7-16 Pwr Rating	7/8” Pwr Rating	Approx. Vert. Height ft / m	Req (*) Tower Space ft/ m	Est. Wind Load lbs/Kg
1	1.5	1.4125	3.64	800 W	2 kW	4 kW	4' 6" / 1.37	14' 4" / 4.37	22.2 / 10.1
2	4.5	2.8183	6.64	1.5 kW	3.8 kW	7.5 kW	13' / 3.97	22' 10" / 6.97	44.4 / 20.2
3	6	3.9810	8.14	2.2 kW	5.5 kW	11 kW	21' 6" / 6.57	31' 5" / 9.57	66.6 / 30.3
4	7.5	5.6234	9.64	2.8 kW	7.4 kW	15 kW	30' / 9.17	39' 11" / 12.17	88.8 / 40.4
5	8.5	7.0794	10.64	3.5 kW	9.2 kW	18.5 kW	38' 7" / 11.77	48' 5" / 14.77	111 / 50.5
6	9.3	8.5113	11.44	4.1 kW	11 kW	22 kW	47' 2" / 14.37	57' / 17.37	133.2 / 60.6
7	10	10	12.14	4.7 kW	13.8 kW	25.5 kW	55' 8" / 16.97	65' 2" / 19.97	155.5 / 70.7
8	10.5	11.2201	12.64	5.3 kW	14.5 kW	29 kW	64' 2" / 19.57	74' / 22.57	177.6 / 80.8
10	11.3	13.4896	13.44	6.8 kW	18.2 kW	36 kW	81' 3" / 24.77	91' 1" / 27.77	222.2 / 101
12	12.3	16.9824	14.44	7.5 kW	22 kW	40 kW	98' 4" / 29.97	108' 2" / 32.97	266.4 / 121.2

Values shown are typical. Actual values may vary with each specific installation. Power ratings are for single carrier. Attenuation of connecting cables not taken into account. Gain will be affected if null fill, beam tilt, special H / V ratio or special wavelength spacing is required. Gain is provided for one polarization and is equal in circularly polarized antennas for both horizontal and vertical components. If antenna is side mounted, the supporting structure will have a slight effect on radiation pattern and on VSWR. Contact us with details of your installation for customized data. (*)Total tower space recommended allows 5 ft (1.5 m) of clear tower space above and below the mounting area to protect from pattern interference by other antennas. On multi-bay arrays, we suggest extending support pipe min. 5 ft (1.5 m) above the top bay and below the bottom bay. Est. wind loads are calculated per EIA Standard RS-222-C for 100 mph (160 kph).

For more information contact **BEXT Inc San Diego CA USA · Tel 619 2398462 Fax 619 2398474 · www.bext.com · e-mail: bext@bext.com**