



# TFC2K-D

*Circularly Polarized  
Mildly Directional,  
Stainless Steel, Broadband  
FM Antenna 87.5 - 108 MHz*



Lightning Protection – All metal parts DC grounded  
Null fill, beam tilt & custom applications upon request  
Arms can be disassembled for easier transport  
Pressurization available upon request  
Pattern: Mildly directional

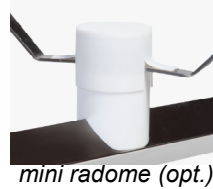

Impedance: 50 Ohm • VSWR: < 1.28: 1  
Optional mini radome on feedpoint available  
Available input connectors (each bay): “N” (F), 7-16 (F) or 7/8” Flange  
Average center to center distance (multi-bays): 8 ½ ft (2.6 m.)  
Bracket (included): can clamp on 1” to 4 3/16” (25mm to 110mm) diam.  
Approx size: (1 bay) 83” x 65½” x 65½” (2010mm x 1660mm x 1660mm)  
Typical boxed size: (1 bay) 96”x 18”x 18” (2440mm x 460mm x 460mm)  
Typical weight, 1 bay, boxed: 72 Lbs/33 Kg

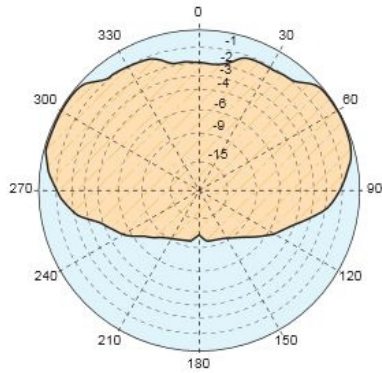

**Typical mid-band  
radiation pattern  
< H-Plane  
E-Plane >  
(each bay)**

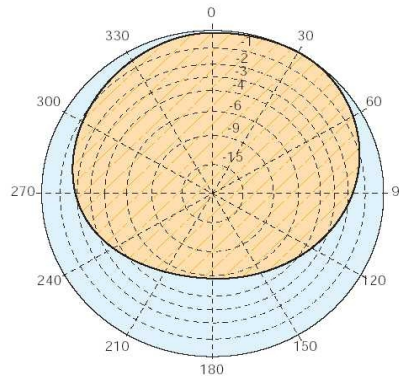

N. of Bays	Gain (dBd)	Power Gain	Gain (dbi)	“N” Pwr Rating	7-16 Pwr Rating	7/8” Pwr Rating	1-5/8” Pwr Rating	Approx. Vert. Height ft / m	Req (*) Tower Space ft / m	Est. Wind Load lbs/Kg
1	-1.69	0.6776	0.45	800 W	2 kW	4 kW	7 kW	3’ 10” / 1.16	13’ 8” / 4.16	102 / 46
2	0.99	1.2560	3.13	1.5 kW	3.8 kW	7.5 kW	12 kW	12’ 4” / 3.76	22’ 2” / 6.76	205 / 93
3	2.64	1.8365	4.78	2.2 kW	5.5 kW	11 kW	19 kW	20’ 10” / 6.36	30’ 8” / 9.36	308 / 140
4	3.85	2.4266	5.99	2.8 kW	7.4 kW	15 kW	25 kW	29’ 5” / 8.96	39’ 3” / 11.96	411 / 186
5	4.79	3.0130	6.93	3.5 kW	9.2 kW	18.5 kW	31 kW	37’11” / 11.56	47’ 9” / 14.56	514 / 233
6	5.56	3.5974	7.7	4.1 kW	11 kW	22 kW	38 kW	46’ 5” / 14.16	56’ 3” / 17.16	617 / 280
7	6.23	4.1975	8.37	4.7 kW	13.8 kW	25.5 kW	44 kW	55’ / 16.76	64’ 2” / 19.56	720 / 327
8	6.8	4.7863	8.94	5.3 kW	14.5 kW	29 kW	50 kW	63’ 6” / 19.36	73’ 4” / 22.36	823 / 374
10	7.76	5.9703	9.9	6.8 kW	18.2 kW	36 kW	63 kW	80.7” / 24.56	90’ 5” / 27.56	1029 / 467
12	8.56	7.1779	10.7	7.5 kW	22 kW	40 kW	75 kW	97’ 8” / 29.76	107’6” / 32.76	1235 / 561

Values shown are typical. Actual values may vary with each specific installation. Power ratings are for single carrier. Attenuation of connecting cables not taken into account. Gain will be affected if null fill, beam tilt, special H / V ratio or special wavelength spacing is required. Gain is provided for one polarization and is equal in circularly polarized antennas for both horizontal and vertical components. If antenna is side mounted, the supporting structure will have a slight effect on radiation pattern and on VSWR. Contact us with details of your installation for customized data. (\*)Total tower space recommended allows 5 ft (1.5 m) of clear tower space above and below the mounting area to protect from pattern interference by other antennas. On multi-bay arrays, we suggest extending support pipe min. 5 ft (1.5 m) above the top bay and below the bottom bay. Est. wind loads are calculated per EIA Standard RS-222-C for 100 mph (160 kph).